

Hollywood Sport Rider 2 Bike Rack

Not to be used on any trailer, fifth wheel or vehicle being towed by another vehicle.
Weight Limit 45 lbs. per bike Fits both 1 1/4" and 2" hitch receivers Model No. HR1000

When you open your Hollywood Sport Rider 2 box, you should have the following:

1. Main rack with wheel holders and wheel holder support tubes.
(Velcro® straps are attached to the wheel holders, but are NOT shown in images)
2. Insert tube for 2" receiver (remove black "U" spacer for use on 1-1/4" receiver).
3. Short hook assembly.
4. Long hook assembly.
5. Hardware bag with the following:
 - a. Hitch bolt for 1-1/4" receiver (1-1/2")
 - b. Hitch bolt for 2" receiver (2-1/4" long)
 - c. Washer for hitch pin (1" dia.)
 - d. Lock Washer for hitch bolt (3/4" dia.)
 - e. 2 bolts to attach insert tube (2-1/4")
 - f. 2 nyloc nuts for attachment bolts (1/2")
 - g. 6 black plastic nut caps (5/16")
 - h. 2 black plastic nut caps (1/4")
 - i. 1 security strap with 2 part side release buckle
 - j. 4 each 5/16-18 nuts for alternative wheel holder fastening

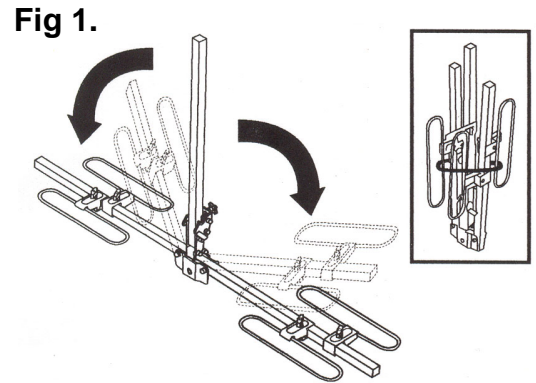

1. The wheel holder tubes are hinged onto the main rack frame (1.). Fold down the wheel support tubes away from the main rack, to a horizontal position. See **Fig. 1**.
2. Install the long hook (4.) on the main vertical tube and position towards the rear of the rack (**Fig. 2**). The hook's exact position on the tube is not important at this time.
3. Place the security strap (i.) next on the same vertical tube, the small end loop over the tube (the small loop end has the female part of the buckle sewn to it). *Use this strap to keep wheel support tubes together while not in use - see fig. 1*

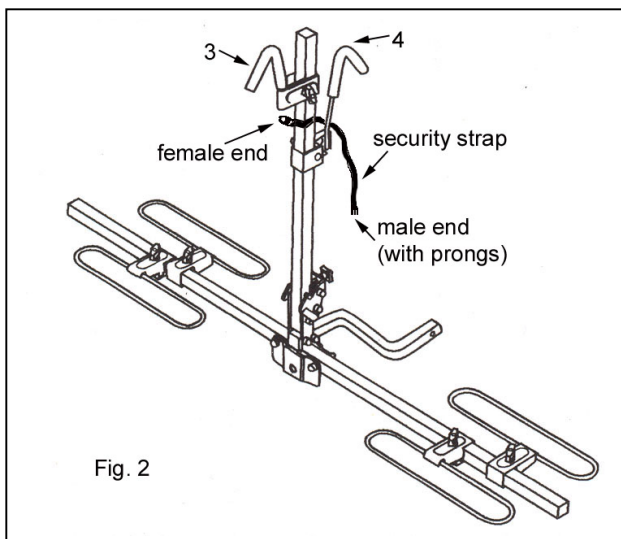

4. Install the short hook (3.) on the vertical tube, facing the opposite direction from the large hook. See **Fig. 2**.
5. Loosen adjustment knob and fold the vertical tube on the main rack down to a horizontal position. See how to use the knob in **Fig. 4**.
6. Fit end of the insert tube (2.) with the two small holes to the main rack and attach with 2 bolts (e.) and nyloc nuts (f.) using a 1/2" or adjustable wrench. Tighten securely. See **Fig. 3**.

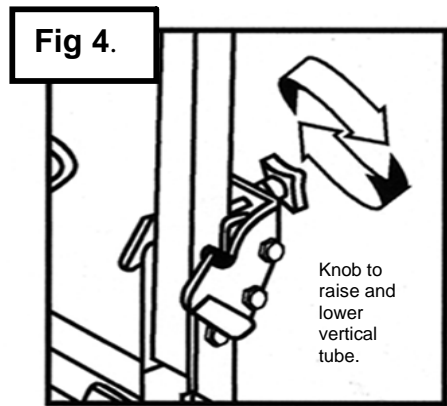
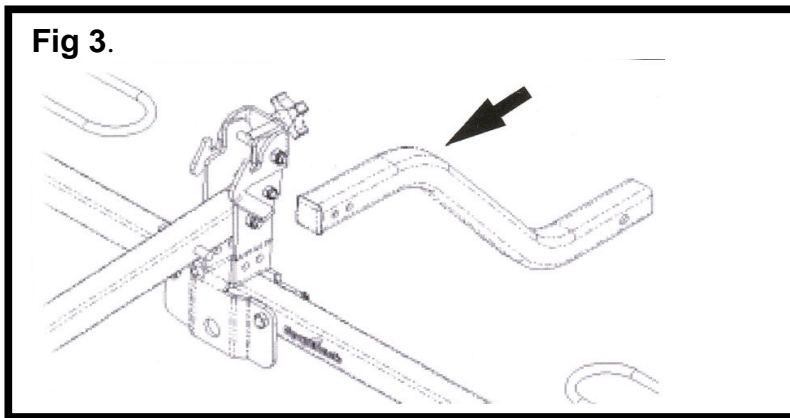

6. continued: When all the nuts and bolts are tight, press the black plastic nut caps (g. and h.) on to the exposed nuts and bolts on the rack. These are a simple press fit, and should snap into place with a minimal application of force.

Fitting the Hollywood Sport Rider to your vehicle:

7. Now that the basic rack is assembled, it's time to fit the rack to your vehicle. **If your vehicle has a 2" receiver**, simply insert the insert tube (2.) of the rack into the receiver of your vehicle. If your vehicle has a 1-1/4 receiver, proceed directly to instructions 9. / 10. Line up the large hole at the end of the insert tube with the hitch bolt hole in your receiver.

8. Take the large bolt (b.) with 3/4" head (threaded hitch bolt), and slide on first the lock washer (d.), and then the large flat washer (c.) See **Fig. 5**. When the washers are installed, install the threaded hitch bolt through the hitch bolt hole in your receiver, then thread it into the insert tube of the rack. Tighten securely.

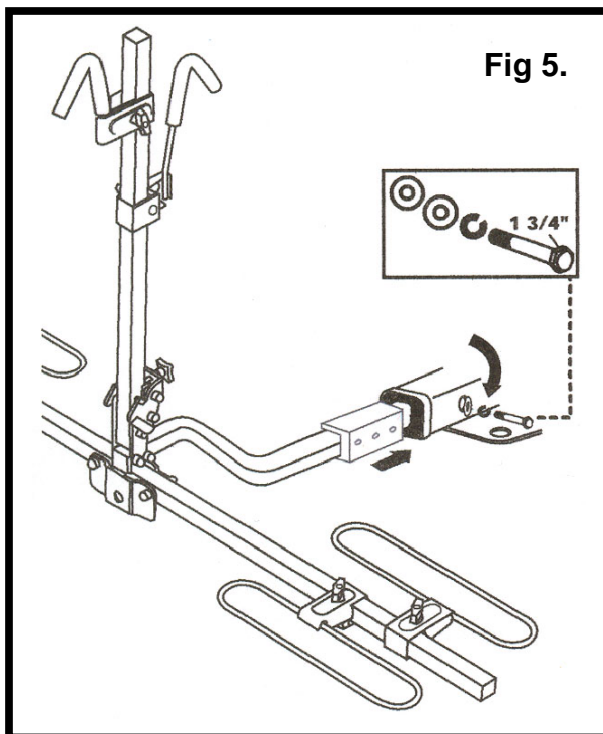

Instructions for vehicles with 1-1/4" receiver:

9. If your vehicle has a 1-1/4" receiver, you will need a Phillips head screwdriver to remove the 2" spacer first. The spacer is the black U-Shaped plastic piece attached to the end of the insert tube (2.). Simply unscrew the Phillips head screw that is holding the spacer to the end of the insert tube.

10. Take the shorter (a.) of the two threaded hitch bolts (1-1/2" long) and slide on first the lock washer (d.), and then the large flat washer (c). When the washers are installed, install the threaded hitch bolt through the hitch bolt hole in your receiver, then thread it into the insert tube of your rack. Tighten securely.

Fitting bikes to the Hollywood Sport Rider:

11. To fit the first bike (closest to the vehicle) more easily, the vertical tube of the main rack may be tilted down (away from vehicle). To do this, simply loosen the black knob at the bottom of the main rack (see Fig. 4), then depress the release lever and fold the vertical tube to a horizontal position. **Note: Never fold down main tube with bike(s) mounted.**

Place the first bike in the wheel holders, then rotate the vertical tube up. When it reaches the top, it will "snap" into place. **At this point, it is important to re-tighten the black knob securely.**

See Fig. 4.

12. Always position the smaller bike between the bicycle support (vertical tube of main rack, 1.) and the car bumper, using the larger hook. For bicycles with a slanted top tube (i.e. ladies bikes and some mountain bikes), **position hook at the lowest point** of the top tube, as far down a possible.

13. When you have found the correct position for the bicycle frame, adjust

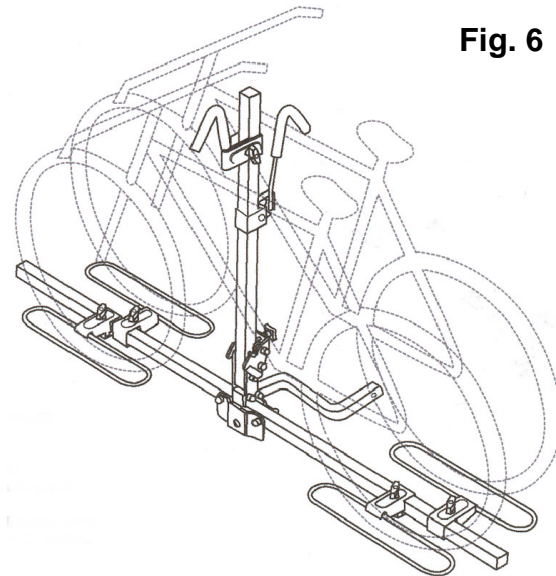

Fig. 6

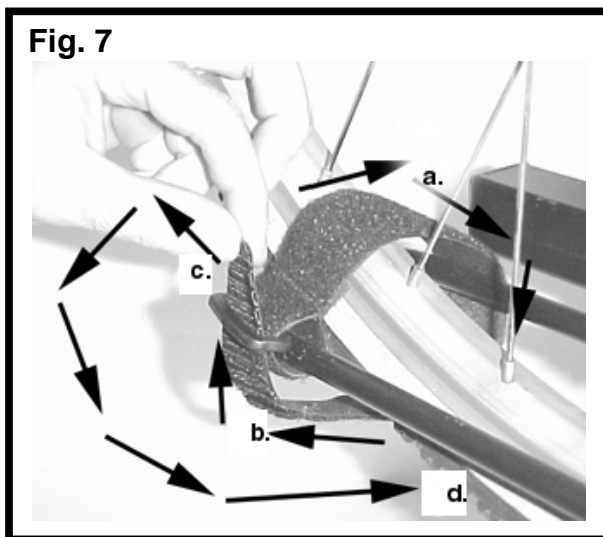

Fig. 7

the wheel holders such that they are directly beneath each wheel. To adjust the wheel holders, loosen the knobs and slide along the wheel holder support tube. Tighten knobs securely. For more permanent wheel holder position, remove knobs and install (j) nuts and nut covers. An adjustable wrench, 1/2" or 13 mm wrench or socket required. Be sure to tighten nuts securely.

14. With the bicycle sitting in the wheel holders, and the large hook in the lowest possible position on the bike frame, tighten the quick release lever at the base of the hook, turning the knob until it is snug, then clamping (closing) the quick release lever to make it absolutely tight. See **Fig. 6** showing bikes mounted on the Sport Rider rack.

15. Use the Velcro® wheel straps that are attached to the wheel holders to wrap around each bike's wheel/tire and strap them down securely as follows:

- a. Wrap strap through spokes and around wheel holder.
- b. Bring strap up around tire, and through plastic loop.
- c. Bring strap down after passing through loop.
- d. Attach Velcro® firmly. See **Fig. 7**.

16. Use the security strap as the final component to secure the bikes to the rack. Thread it through all the bicycle wheels and frame(s), plug the male part into the female part, then pull strap end to tighten until snug.

17. Double check before driving off:

- A) Hook quick release levers are tight for both bikes.
- B) All wheel straps are fastened through wheels and tires on wheel holders.
- C) Security strap is attached, strapping both bikes securely to the rack.

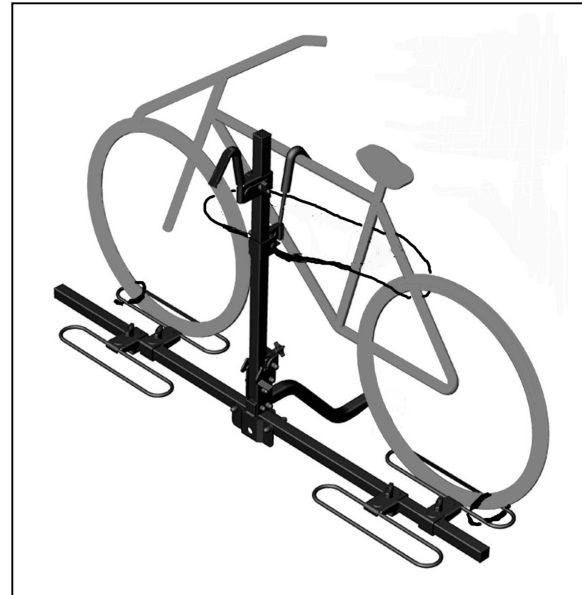

18. Use the security strap to keep the wheel support tubes together in vertical position when rack is not in use.

19. Warnings:

- **This product is NOT to be used on any trailer, fifth wheel or vehicle being towed by another vehicle**
- **Drive slowly on bumpy or dirt roads.**
- **Do not exceed the 45 lb per bike weight capacity**

Limited One Year Warranty:

This rack is warranted for a period of one year against defects in materials and workmanship, effective from the date of purchase to the original purchaser. The manufacturer will repair or replace any defective parts due to materials or workmanship. The manufacturer of this product shall not extend the warranty to 1) Any failure or malfunction of the product due to any of or modifications to the product; or 2.) Damages not attributable to a defect in materials or workmanship; or 3.) Damages resulting from improper installation on vehicle or attachment of bicycles on rack. **Consequential or Incidental Damages:** The manufacturer shall not be liable for any consequential or incidental damages in connection with the purchase, use or handling of this bike rack. **Purchaser's Rights:** Some states do not allow the exclusion or limitation of consequential or incidental damages and the above limitation may not apply to you. This warranty gives you specific legal rights and you have other rights, which vary from state to state.

Hollywood Engineering PO Box 627 Gardena, CA 90248
Phone: 800-747-4085 FAX 310-516-8955
www.hollywoodracks.com

