

HOLLYWOOD RACKS

Installation instructions for the Model F6 Bicycle Carrier

Caution: This rack is not to be mounted to any trailer or towed vehicle!

When using the F6 Expedition Bumper Rack always remember the following points:

1. Install the rack on structurally sound areas only.
2. **Never** install the upper hooks to plastic, aluminum, glass or fiberglass.
3. Clean the surface of the trunk and bumper prior to installation.
4. Tighten all straps before and **after** mounting bicycles on the rack
5. Never place more than a total of 100 lbs. (45 kgs.) on the rack.
6. Keep the bicycle tires away from exhaust pipes (1 foot or 30cm) minimum.
7. Check the rack, bikes and strap tightness regularly during use.
8. Use caution and reduce speed on rough roads.

If you have any questions or installation problems, please call your Hollywood Racks retailer or call Hollywood Engineering at: 1-800-747-4085.

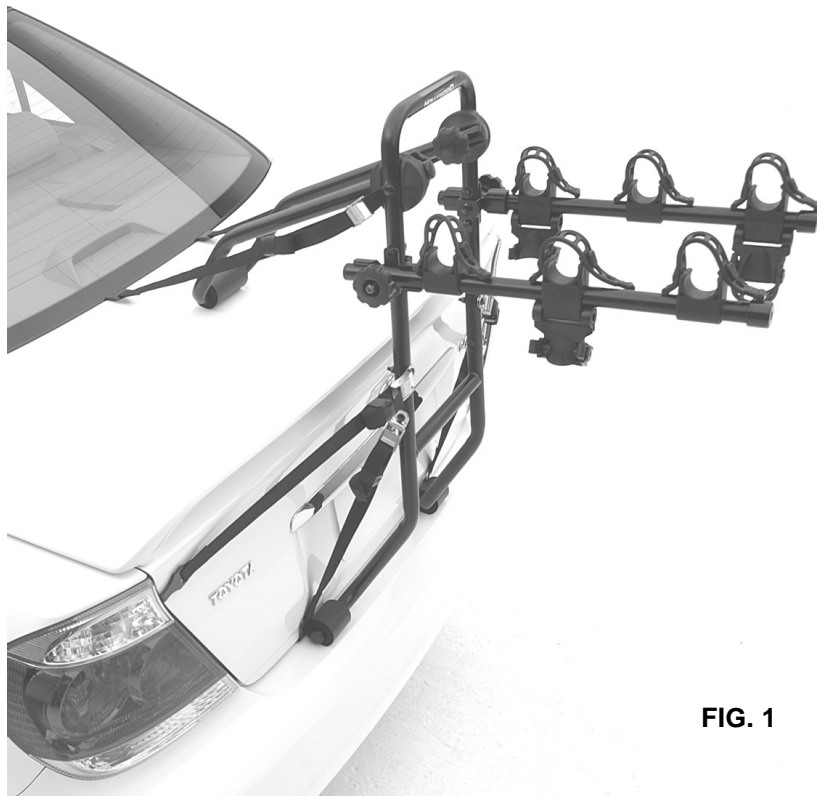

FIG. 1

Before installing the Hollywood F6 Expedition bumper rack:

Be sure that your vehicle has structurally sound trunk and bumper areas. Clean the trunk and bumper surfaces where the rack will rest. **Note:** It may be necessary to look under your vehicle to determine the strength of the vehicle's bumper. Lower straps can be attached to lower trunk lid opening.

Installing the Expedition bumper rack:

1. Loosen the knobs on both sides of the rack.
2. Place the main frame on the vehicle's bumper so that the main frame is perpendicular to the ground. Rotate and

position the rear brace of the rack so it rests on the trunk / door (Fig. 1.). The main frame should be in a somewhat vertical position. Tighten the knobs on the rear brace to locate the rear brace. Knobs should be snug and tight, but do not over-tighten (Fig. 2).

3. Attach the upper hooks to the top of the trunk, hatch or rear door. Pull the loose strap end, and tighten the strap securely (Fig. 3). Place the lower straps under the bumper or at the bottom of the rear door. Pull down on the straps to tighten. Install the side straps horizontally from the rack to the trunk or rear door and tighten until snug.
4. Raise the bicycle support arms so they are parallel to the ground or angled slightly up at the rear. Tighten the knobs securely. Some minor adjustment of the rack, straps and / or support arms may be necessary at this point, to obtain a good fit.

Caution: Always re-check all rack-to-car straps for correct tension after installation!

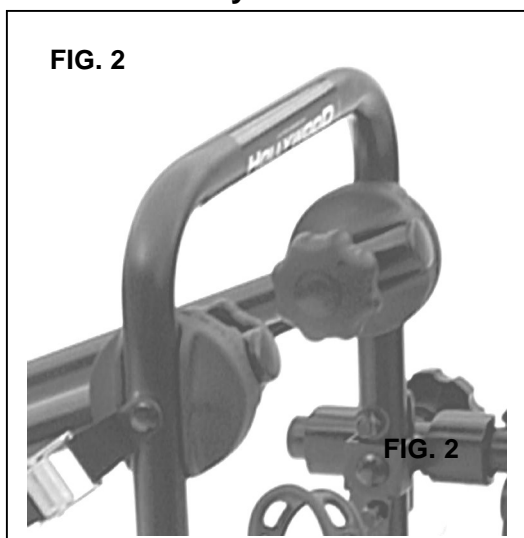

FIG. 2

FIG. 2

Installing bicycles on the Hollywood F6 Expedition bumper rack:

1. Install the individual tie down straps on the cradles and anti-sway blocks.
2. The heaviest bicycle should be loaded on the rack first, with the lightest on the outside. Place the first bicycle on the inside cradles, closest to the main frame of the rack. The handlebars should be on the passenger's side of the vehicle. Rotate the crank arm so that it doesn't contact the vehicle.
3. Pull the strap around the frame and hook it onto the small anchor on the other side of the cradle (Fig. 4). Note that it may be necessary to rotate the cradle and

strap position to fit around the bicycle frame.

- Pull the strap so that it's snug, but do not over-stretch the strap. Over-stretching the strap will not hold the bike on any better, and it may compromise the strength and life span of the strap. Adjust the other tie down straps accordingly.
- Use the Anti-Sway block that sits below one of the cradles (for each bike) to stabilize the bike by placing the strap around the seat tube (*not* seat post) of each bike (**Fig. 5**). You may need to rotate the Anti-Sway block, and in some cases you may need to remove it completely. This would be the case on very small bikes, or bikes with restricted mounting space due to creative frame design.

- Install the second bicycle with the handlebars on the driver's side. Adjust the tie down straps as per the first bicycle. Repeat the installation for the third bicycle, with the handlebars again on the passenger's side of the car.

- VERY IMPORTANT:** You must use the long (86" x 1") black strap to secure the lower portions of ALL the bicycles to the rack. This strap must be routed behind the main frame, through the bicycle wheels and pulled tight.

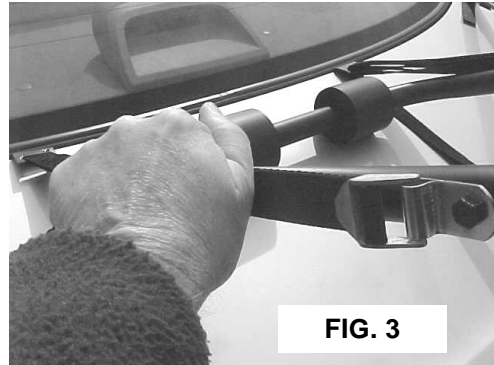

- Tighten all straps before and after mounting the bicycles on the rack.**

Tip: Women's bicycles, children's bicycles, and small frame size bikes, can be mounted on the rack by placing the bicycles on the support arms under the bicycle's down tube and behind the seat tube.

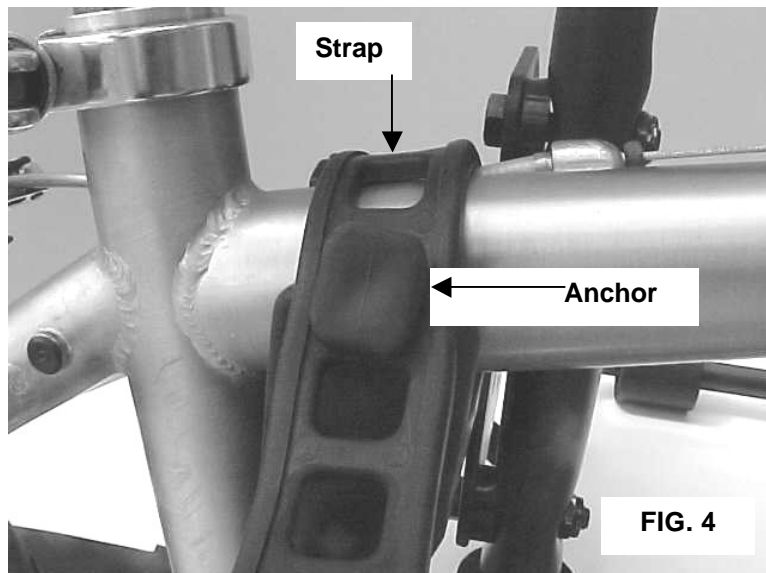

Removing and storing the F6 Expedition bicycle rack:

- After removing bicycles, lift up on the release tabs of the lower buckles. Unhook the straps from the bumper / door.
- Loosen the knobs and lower the support arms to their folded position.
- Retighten the knobs.
- Lift the release tab on the side and top straps and remove hooks and straps from vehicle.

Caution: This bicycle rack is designed to carry three (3) conventional bicycles. Do not attempt to carry

motorcycles, scooters, mopeds, motorized wheelchairs, or other heavy objects. Always check the condition of the straps and stitching and replace as necessary. Replacement parts are available from Hollywood Engineering. If you need parts, please call Customer Service: 800-747-4085 Mon. – Fri. From 7:00AM – 3:00PM Pacific Time.

- To fold the support arms down, loosen the knobs on the outside of the rotating pivot to which the arms are mounted. A few turns of the knob should be sufficient to allow the arms to pulled out slightly.
- When arms are released by loosening the knobs, rotate them to the vertical position and retighten the knobs securely.

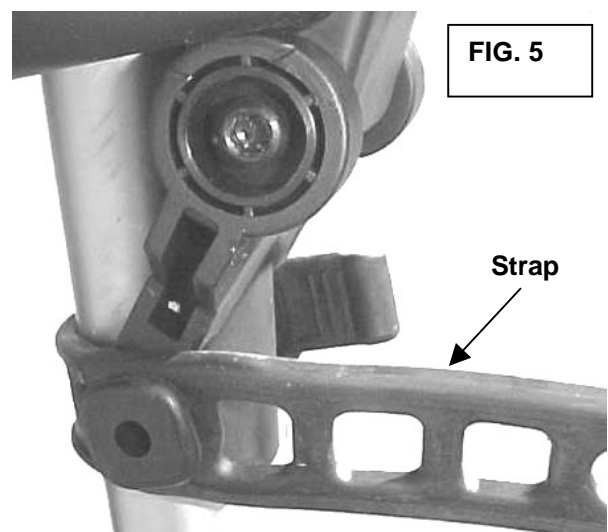

Limited One Year Warranty: This rack is warranted for a period of one year against defects in materials and workmanship, effective from the date of purchase to the original purchaser. The manufacturer will repair or replace any defective parts due to materials or workmanship. The manufacturer of this product shall not extend the warranty to 1) Any failure or malfunction of the product due to any modifications to the product; or 2.) Damages not attributable to a defect in materials or workmanship; or 3.) Damages resulting from improper installation on vehicle or attachment of bicycles on rack. **Consequential or Incidental Damages:** The manufacturer shall not be liable for any consequential or incidental damages in connection with the purchase, use or handling of this bike rack. **Purchaser's Rights:** Some states do not allow the exclusion or limitation of consequential or incidental damages and the above limitation may not apply to you. This warranty gives you specific legal rights and you have other rights, which vary from state to state.

Hollywood Engineering PO Box 627 Gardena, CA 90248
Phone: 800-747-4085 FAX 310-516-8955
www.hollywoodracks.com