

Traveler Bicycle Hitch Rack

Assembly and Installation instructions

WARNING! THIS PRODUCT IS **NOT** TO BE USED ON ANY TRAILER

PLEASE FOLLOW THESE IMPORTANT POINTS:

- DRIVE SLOWLY WHEN USING THE RACK ON BUMPY OR DIRT ROADS.
- CHECK THE RACK, BIKES AND STRAPS REGULARLY DURING USE.
- IF YOU HAVE ANY QUESTIONS OR INSTALLATION PROBLEMS, PLEASE SEE YOUR RETAILER OR CONTACT US AT 800- 747- 4085.

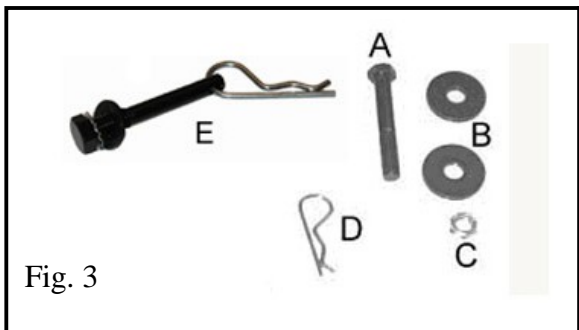
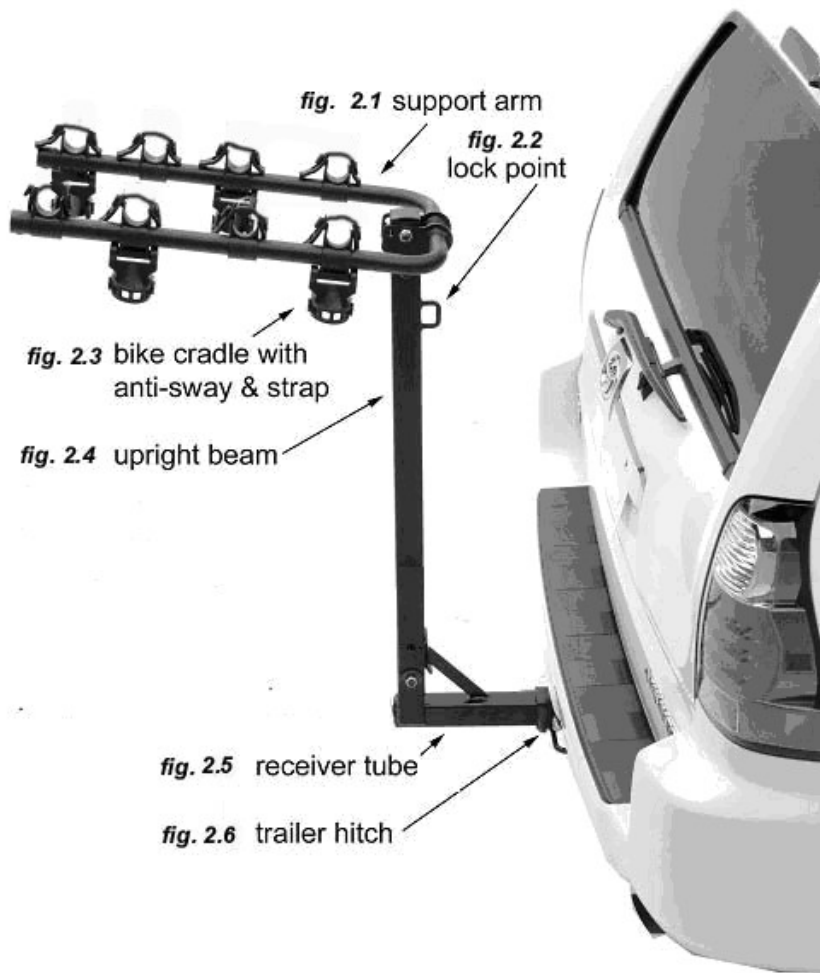

TRAVELER MODEL NUMBERS:

Traveler 3 Series

- HR6000 – 3 bike model for 2" receiver, class 2 or higher
- HR6100 – 3 bike model for 1 1/4" receiver, class 2 (maximum weight of bikes 150 lbs.)
- HR6500 – 3 bike model for both 1 1/4 and 2" receivers

Traveler 4 Series

- HR8000 – 4 bike model for 2" receiver, class 2 or higher
- HR8180 – 4 bike model for 1 1/4" receiver, class 2 (maximum weight of bikes 150 lbs.)
- HR8500 – 4 bike model for both 1 1/4 and 2" receivers

Fig. 2

After opening the box, you should have the following parts:

1. Upright beam assembly with upper support arms installed.
2. Receiver tube assembly (se fig. 4a, 4b, 4c)
3. Parts bag including through bolt, washers and nut, threaded hitch pin/washers/clip (see Fig. 3).
4. Strap bag. Traveler 3 has 9 rubber straps; Traveler 4 has 12 straps.
5. An additional tie-down “safety strap” is attached to the rack at the lock point Fig. 2.2

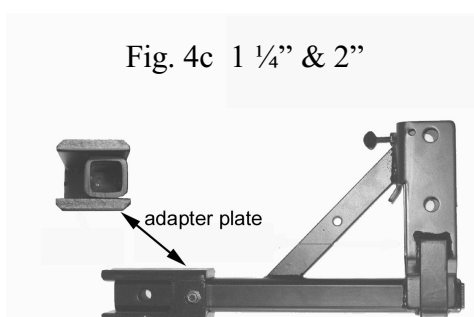
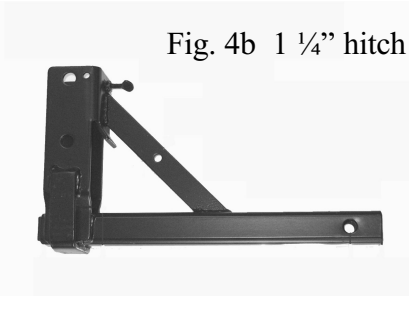
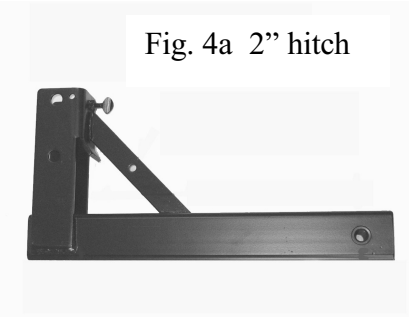

ASSEMBLY: Tools required:
Two 6” adjustable wrenches or 3/4” wrenches

1. The Traveler rack is easily assembled on your work-bench or any flat surface. To assemble the rack, lay the upright beam face down on the bench (Hollywood decal facing down). Place the receiver tube’s bracket on to the end of the upright beam so that the receiver tube is pointing up.

2. Place a washer **B** on the end of **A**, then insert the bolt through the **lower** hole of this bracket and pass it through the **lower** hole of the upright tube. Once the bolt is protruding through the other side of the bracket, install the other washer and nut **C**. Tighten the nut securely on the bolt and use an adjustable wrench or 3/4” wrench to tighten the nut and bolt. Insert the lynch pin through the **upper** hole, and install lynch pin clip **D** in hole at the end of the lynch pin.

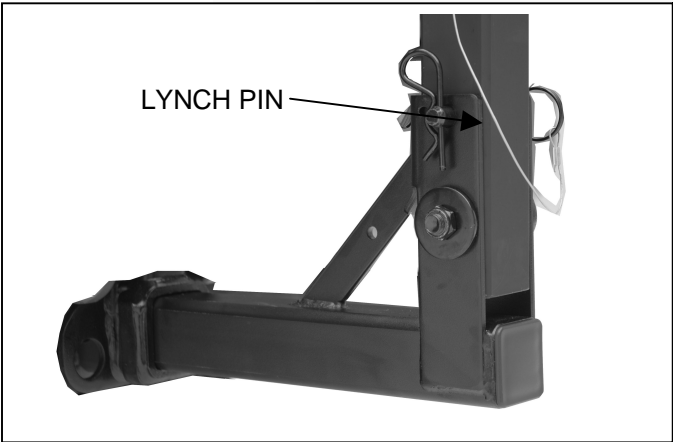

Fig. 5

INSTALLING THE RACK ON YOUR VEHICLE:

1. Within the parts bag, locate the Threaded Hitch Pin (E).
2. Insert the Receiver tube into the hitch. Align the holes of the hitch and receiver tube.
3. Place the flat washer against the head of the bolt, Then the lock washer (this washer has “teeth) against The flat washer, then insert the threaded hitch pin into the receiver tube, tighten securely with either an adjustable wrench or 3/4” wrench. Then install the hitch pin clip into the hole of the hitch pin. See Fig. 6.

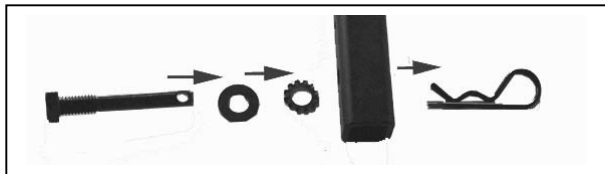

Fig. 6

4. *Note for Models HR6500 and HR8500: these racks are pre-assembled at the factory for use on a 2” hitch. If you have a 1 1/4” hitch, simply remove the adapter plate (fig. 4c) using the attached hex key.*

Support Arms (Fig. 2.1)

Rotate the support arm and align the plate holes with the tube holes per Fig. 7a. Insert pin and close safety clasp over pin end. To return the support arm to it's folded position, undo the safety clasp, then hold the arm with one hand and remove the pin so the arm doesn't drop quickly). Re-insert the pin per Fig. 7b.

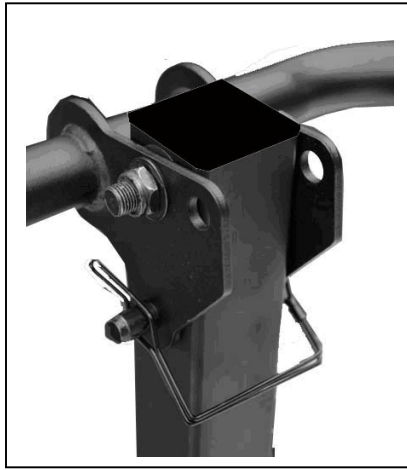

Fig. 7b "folded position"

Fig. 7a "in use position"

INSTALLING BIKES ON THE RACK:

1. For ease of installation, we suggest you put the bigger bikes on the inside (closest to vehicle), smaller frames or kids bikes on the outside. The first bike loaded should have the handlebars facing towards the driver's side of the vehicle. Place the top tube (or closest appropriate frame tube) onto the bike cradles, install the straps over the bike tube and attach to the anchor tabs on both sides of the cradle. Use a strap notch-hole that provides a snug fit, but take care not to pull the strap over-tight. This can put undue stress on the bike's paint, and may over-stretch the strap, making it more susceptible to breakage. Be sure to use the Anti-Sway blocks (below the support arms) to strap the bikes seat tube (or other frame tube as appropriate) to prevent the bikes from swaying on the **Traveler** rack. Note Fig. 8a & 8b below for correct application of the straps on the anti-sway blocks.

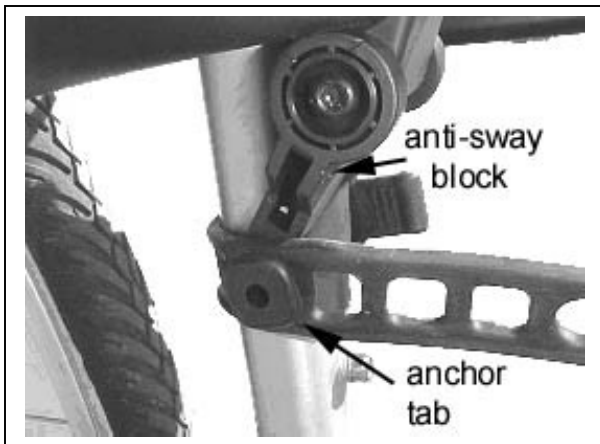

Fig. 8a

Note:
Use **Anti-sway blocks** to keep bikes stable while vehicle is in motion. Be careful not to over-stress the straps!



Fig. 8b

2. After all the bikes have been installed, use the safety tie down strap (attached to the lock point Fig. 2.2 and wrap it through the frames all of the bikes. Attach to the buckle then tighten securely.

REMOVING THE BIKES AND RACK

To remove the bikes, simply undo the straps and gently lift the bikes off. If you're in a parking lot, be sure to fold down the support arms and fold up the wheel brace so as to minimize the

length of the rack when not in use. To remove the rack from the vehicle, fold the support arms and lower brace, and remove the threaded hitch pin. Then slide the rack out of the hitch receiver.

BACKING OUT OF DRIVEWAYS AND GOING OVER BUMPS

Please keep in mind that when transporting bikes, you will be carrying more weight on your hitch. This means the rear of your vehicle will be lower to the ground. When going up driveways or over bumps, drive slowly and at an angle if possible. If you have a car or minivan where the hitch is low to the ground, the rack may hit the ground.

Tilting the Traveler rack down:

Refer to Fig. 5 (page 2): Remove lynch pin clip and lynch pin to tilt the rack down for easy access to the rear of your vehicle.



Fig. 9

Limited Lifetime Warranty (effective January 1, 2008):

Hollywood Racks will warrant its car racks and accessories during the time that an original retail purchaser owns the product subject to the exclusions and limitations of this warranty. Hollywood Racks will remedy defects in materials and workmanship by repairing or replacing (at its option) a defective part or the complete rack without charge for labor or parts. Hollywood Racks may elect (at its option) to issue a refund equal to the purchase price paid for the product.

This warranty does not cover problems caused by normal wear and tear including (but not limited to) weather, scratches, dents, rust, accidents, unlawful vehicle operation, misuse, abuse, neglect, theft, unauthorized modifications, or unauthorized repair. No warranty is given for defects resulting in incorrect assembly, incorrect installation onto the vehicle, installation on a "no fit" vehicle, incorrect attachment of bicycles onto the rack, or overloading of the rack's weight restrictions. This warranty terminates if the original retail purchaser transfers the product to any other person.

If a product is believed to be defective, the original retail purchaser should contact either the original retailer or Hollywood Racks directly at 800-747-4085 or at info@hollywoodracks.com

Disclaimer of Liability: Repair or replacement of a defective product or the issuance of a refund or credit (as determined by Hollywood Racks) is a purchaser's exclusive remedy under this warranty. Damage to a purchaser's vehicle, cargo, bicycles and or to any other person is excluded. This warranty is expressly made in lieu of any and all other express warranties, whether oral or written.

Hollywood Racks shall not be liable for any direct, indirect, consequential, incidental, special, punitive or any other damages in connection with the purchase, use or handling of this product.

Some states do not allow the exclusion or limitation of consequential or incidental damages and the above limitation may not apply to you. This warranty gives you specific legal rights and you have other rights, which vary from state to state.

Hollywood Racks
12812 S. Spring St. Los Angeles, CA 90061
(800) 747-4085 or (310) 516-8600 FAX (310) 516-8955
www.hollywoodracks.com
info@hollywoodracks.com
Customer Service: M-F 8:00 AM – 3:00 PM PST
Made in Taiwan 022008 rev d

Hollywood Traveler. Instructions d'assemblage et d'installation

HR6000	3 vélos pour 2" classe 2 ou plus élevée
HR6100	3 vélos pour 1-1/4" classe 2 ou plus élevée (poids maximum 150 lbs)
HR6500	3 vélos modèle pour 1-1/4" et 2"
HR8000	4 vélos pour 2" classe 2 ou plus élevée
HR8100	4 vélos pour 1-1/4" classe 2 ou plus élevée (poids maximum 150 lbs)
HR8500	4 vélos modèle pour 1-1/4" et 2"

Attention! Ne jamais monter ce produit sur une remorque ou un véhicule remorqué

Suivre les directives suivantes:

Conduire doucement sur chaussée en mauvais état ou chemin de terre.

Vérifier le porte-vélo, les vélos et les sangles régulièrement pendant utilisation.

Après avoir ouvert la boîte, vous trouverez les pièces suivantes:

1. Poteau central (Fig 2.4) avec bras de supports installés (Fig.2.1)
2. Tube pour attelage remorque Fig.5 avec système anti-jeu (Fig 4a, 4b ou 4c)
3. Sachet de pièces comprenant le boulon A, rondelles B, écrou C, Cheville anti-jeu E et agrafe D.
4. Sachet de sangles contenant. Sangle d'attache (caoutchouc et nylon) Traveler 3 possède 9 sangles en caoutchouc et 4 sangles en nylon: le Traveler 4 possède 12 sangles en caoutchouc.
5. Une sangle supplémentaire en nylon de 86" de sécurité attaché au porte-velo Fig 2.2

Assemblage: Outils nécessaire: Clefs à mollettes de 6" ou équivalent

1. Le Traveler est facilement assemblé sur une surface plate. Pour assembler le porte-vélo, poser le Poteau vertical (Fig 2.4) à plat, face vers le bas (Hollywood decal vers le bas). Placer le tube pour attelage (Fig 4a, 4b ou 4c) à l'extrémité du Poteau principal (Fig 2.4) de façon à ce que le tube pour attelage soit perpendiculaire au Poteau.
2. Place une rondelle B au bout du boulon A, ensuite insérer le boulon A à travers le trou inférieur sur le tube de l'attelage 4a, 4b ou 4c et le trou inférieur du Poteau vertical Fig 2.4. Une fois que le boulon a traversé de l'autre côté du tube pour attelage, installer l'autre rondelle B et l'écrou C. Serrez fermement le boulon et l'écrou à l'aide d'une clef de 3/4" ou d'une clef à mollettes. Insérer la broche (sur le Poteau vertical) à travers le trou supérieur du tube de l'attelage et à travers le Poteau vertical et de l'autre côté du tube de l'attelage. Installer l'agrafe D dans le trou de la broche.

Installer le porte vélo sur votre véhicule.

1. Trouver la cheville anti-jeu E.
2. Insérez le porte vélo dans l'attache remorque 2.6. Aligner le trou du tube pour l'attelage Fig 2.5 au trou de l'attelage Fig 2.6
3. Placer la rondelle plate dans la cheville E en premier ensuite insérer la rondelle dentée dans la goupille E comme sur la Fig 6. Insérer dans les trous alignés du tube pour l'attelage Fig 2.5 au trou de l'attelage Fig 2.6 et serrez fermement. Installer ensuite 'agrafe de l'autre côté. voir Fig.6
4. Note pour les modèles HR6500 et HR8500: Ces porte-velos sont pré-assemblés à l'usine pour utilisation sur attelage 2". Si vous avez un attelage de 1-1/4", enlever simplement l'adaptateur (Fig 4c) en utilisant la clef incluse.

Installer les vélos sur le porte-vélo.

1. Enlever la broche Fig 7a, et faire pivoter les bras de supports dans une position horizontale ou d'utilisation. Réinsérer la broche 7a et attacher le fermoir de sécurité.
2. Attacher les sangles de caoutchouc aux berceaux porteurs sur les bras de support à travers un trou rond a l'extrémité de la sangle avant de monter les vélos. Attachés les sangles des berceaux du côté du véhicule seulement.. Placer le vélo le plus lourd en premier (le plus proche du véhicule), en mettant le tube supérieur du cadre sur les berceaux en caoutchouc. Le guidon doit être du côté du conducteur. Attacher fermement les 3 sangles en caoutchouc. Répéter les mêmes instructions pour le (s) prochain vélo (s) en le mettant dans l'autre sens (guidon vers le passager)
3. Attacher la sangle d'attache des vélos de 86". **Important: Après que tous les vélos soient bien installés, attacher la sangle de 86" autour du Poteau vertical ET de tous les vélos. Serrer fermement.**
4. Se référer a la Fig.5. Pour incliner le porte-vélo, enlever l'agrafe D et la goupille du Poteau central, et aider le Poteau central à s'incliner gentillemet pour accès à l'arrière du véhicule.

Important:

Le fabricant de ce produit n'est pas responsable des dommages causés par le mauvais usage de ce produit. C'est la responsabilité de l'utilisateur de s'assurer que le porte vélo est monté proprement sur le véhicule et que les vélos soient proprement chargés sur le porte vélo comme décrit dans ces instructions d'installation.